



Manual de Usuario

UPS ESOL RTH-L

Baterías Ion -Litio
1-3 kVA

Foreword

Summaries

Thank you for choosing an KR-RM Li Series UPS!

This document gives a description of the KR-RM Li Series (1-3kVA) UPS (hereinafter referred to as UPS), including the features, performance, appearance, structure, working principles, installation, operation, maintenance, transportation and storage, etc.

Please save the manual after reading, in order to consult in the future.









NOTE

The figures in this manual are just for reference, for details please see the actual product.

Symbol Conventions

The manual quotes the safety symbols, these symbols used to prompt users to comply with safety matters during installation, operation and maintenance. Safety symbol meaning as follows.

Symbol	Description
 DANGER	Alerts you to a high risk hazard that could, if not avoided, result in serious injury or death.
 WARNING	Alerts you to a medium or low risk hazard that could, if not avoided, result in moderate or minor injury.
 CAUTION	Alerts you to a potentially hazardous situation that could, if not avoided, result in equipment damage, data loss, performance deterioration, or unanticipated results.
	Anti-static prompting.
	Be care electric shock prompting.
 TIP	Provides a tip that may help you solve a problem or save time.

Symbol	Description
 NOTE	Provides additional information to emphasize or supplement important points in the main text.

Change History

Changes between document issues are cumulative. The latest document issue contains all the changes made in earlier issues.

Issue 001 (2018-01-06)

First issue.

Contents

1 Safety Description.....	1
1.1 Safety Announcements.....	1
1.1.1 UPS Announcements.....	2
1.1.2 Battery Announcements.....	3
1.1.3 ESD Protection.....	4
1.1.4 Measurement When Power On.....	4
1.2 Operation Announcements.....	5
1.3 Operation Environment Requirements.....	6
2 Overview.....	7
2.1 Product Intro.....	7
2.1.1 Features.....	7
2.2 Appearance.....	8
2.2.1 Operation Panel.....	9
2.2.2 Rear Panel View.....	11
2.2.3 EPO Connector.....	13
2.2.4 Intelligent Slot.....	13
2.3 Working Principles.....	14
2.3.1 Fault Status.....	15
2.3.2 UPS Parameters Setting.....	17
3 Installation.....	20
3.1 Installation Announcements.....	20
3.2 Installation Preparation.....	21
3.2.1 Installation Place and Environment Requirements.....	21
3.2.2 Input Breaker Selection.....	22

3.2.3 Selection of the Cross-sectional Area of Wire	23
3.3 Unpacking and Checking	24
3.4 Installation Procedures	24
3.4.1 UPS Installation	24
3.4.2 Intelligent Slot Replacement	26
3.5 Electrical Connection	28
3.5.1 Battery Connection	28
3.5.2 Wire Connection	28
3.6 Electrical Connection Checking	32
4 Operation Guide	34
4.1 Checking Before Startup	34
4.2 Startup Operation	34
4.3 Shutdown Operation	35
5 Maintenance and Troubleshooting	36
5.1 Maintenance Guide	36
5.1.1 Safety Precautions	36
5.1.2 Preventive Maintenance	36
5.2 Daily Battery Maintenance	37
5.3 Replacing Battery Announcements	37
5.4 Troubleshooting	38
6 Package, Transportation, Storage	41
6.1 Package	41
6.2 Transportation	41
6.3 Storage	41
A Technical Specifications	42
B Acronyms and Abbreviations	47

1 Safety Description

This chapter mainly describes safety announcements. Prior to performing any work on device, please read user manual carefully, follow operation and installation instructions and observe all danger, warning and safety information to avoid human injury and device damage by irregular operations.

1.1 Safety Announcements

This section mainly describes safety announcements during operation and maintenance. For details, please refer to safety instructions in the relevant chapters.



CAUTION

Before attempting to operate device, please read safety announcements and operation instructions in this section carefully to avoid accident.

The promptings in the user manual, such as "Danger", "Warning", "Caution", etc. don't include all safety announcements. They are just only the supplement of safety announcements during operation.



Any device damage caused by violating the general safety operation requirements or safety standards of design, production, and usage will be out of warranty range.

1.1.1 UPS Announcements



CAUTION

The input voltage and output voltage of device are dangerous high voltage. Touching high voltage will endanger human life. Before attempting to install or operate device, carefully read this manual and pay attention to all warning signs in the device. Only authorized professionals are allowed to dismantle power device.



DANGER

Device damage or device failure may cause electric shock or fire!

- Before attempting to operate device, check that there is no damage or other potential danger in the device visually.
 - Check that other external devices or circuit connection is safe.
-



DANGER

During a thunderstorm, don't perform high voltage operation, AC power operation or operations in the tower or mast. Besides, in order to avoid device struck by lightning, for the atmosphere will generate a strong electromagnetic field during a thunderstorm, it should prepare lightning protection and grounding system in time.



WARNING

Don't connect with unbalance load, half-wave rectification load or inductive load in the output of UPS, such as air-condition, blower, starter, electric drill, motor, daylight lamp, etc.



WARNING

Don't put finger or tool into rotating fans to avoid human injury or device damage.



WARNING

In case of fire, please use dry power fire extinguisher. If using liquid fire extinguisher, it may cause electric shock.



CAUTION

Make sure that there is no object in the air inlet, air outlet, as well as in the front of fans to keep device with good ventilation.



CAUTION

No liquid or other objects are allowed to enter device.



CAUTION

The device is level A UPS! When it applies to residential building, additional measures should be taken to inhibit the harassment.

1.1.2 Battery Announcements



CAUTION

It should use specified battery! Non-specified battery will damage UPS.

The required charging voltage of different brands and different types of battery are different. Before using battery, ensure that the charging voltage of UPS is suitable for battery. If any doubt, please consult manufacturer for support.



WARNING

Battery operation must be performed in accordance with battery instructions, especially battery wiring. Irregular operation will cause battery damage, even human injury.

- It is prohibited to connect battery+ with battery-. The wiring for battery must be tightened. It is prohibited to touch any two wiring terminals of battery or the bare terminals for wiring simultaneously, or it may cause battery damage or human injury.
- Prevent electrolyte leaking from battery, or the metal objects and circuit board will be corroded by overflowing electrolyte, which will cause device damage and circuit board short circuit.
- Battery should be placed far away from fire and all electrical equipments which easily cause sparks to avoid human injury or unnecessary loss.

1.1.3 ESD Protection



CAUTION

To prevent human electrostatic damaging sensitive components on the circuit board, before touching sensitive components, please wear an anti-static ring, and well connect the other end of the anti-static ring to ground.

1.1.4 Measurement When Power On



CAUTION

There has dangerous high voltage in the device. If touching device accidentally, it may cause electric shock. So, when performing measurement when power on, it must take protection measures (such as wear insulated gloves, etc.)

The measuring device must meet following requirements:

- The range and operation requirements of measuring device meets site requirements;
- The connections for measuring device should be correct and standard to avoid arcing.

1.2 Operation Announcements

There exists high temperature and high voltage inside UPS. During installation, operation and maintenance, please comply with the relevant safety regulations and operation procedures to avoid human injury or device damage. The safety announcements mentioned in the user manual is only as a supplement to the local safety regulations.



CAUTION

The operation and wiring for UPS should be performed by qualified person, which is to ensure that the electrical connection meets the related standards.

The installer should be trained strictly, know all kinds of safety announcements and get right operation methods before performing installation, operation or maintenance.



DANGER

Don't mount and dismantle power wires before switching off power switch. Besides, ensure that wires, wire labels are in accordance with the practical installation before performing wiring.



WARNING

Touching high voltage or mains directly or through damp objects will lead to lethal risk.

- Only authorized professionals are allowed to open UPS! The input and output of UPS are dangerous high voltage. Touching high voltage will lead to lethal risk.
- Before maintenance, please disconnect AC power and battery to isolate power input and measure the output by a voltmeter to ensure that the input power is disconnected and in a safe condition.

- Even if all external power is disconnected, there still exists residual charge inside UPS, which may endanger human life. It is necessary to set UPS aside for enough time (≥ 10 min) to release all charge before dismantling UPS.
- As the battery doesn't isolate with AC input, there may exist dangerous voltage between battery terminal and ground terminal. The battery pack should be insulated when installing or using it for high voltage hazard concern.
- Do not wear conductive objects, such as watches, bracelets and rings during operation.
- The installer should have the operation qualification of high voltage and AC power. Maintenance and repair for power system only can be done by qualified persons.
- High leakage risk! Before performing electrical connection, device must be grounded.



WARNING

Don't drill holes in the device! Inappropriate drilling will damage components inside device. Metal debris generated by drilling entering device will lead to circuit board short circuit.



NOTE

Any change of system configuration, structure or components will affect UPS performance. If the user wants to make any change, please consult manufacturer in advance.

1.3 Operation Environment Requirements

Operation environment makes a certain difference in the life span and reliability of device. So, please avoid using the UPS in following environment:

- The place where the operating temperature and relative humidity are beyond technical specifications (Generally, the operating temperature is $0\sim 60^{\circ}\text{C}$ (Peak operating Temperature is $0\sim 40^{\circ}\text{C}$. Prolonged operation between $40\sim 60^{\circ}\text{C}$ may affect output wattage) and the relative humidity is 0%-95%).
- The place where it is exposed to direct sunshine or in rain.
- The place where it is with vibration or impact.
- The place where it is dust, corrosive material, salt or burnable gas.
- The place where it is in the poor ventilation or closed place.

2 Overview

This chapter mainly describes the model meaning, features, structure and working principle, etc.

2.1 Product Intro

The (1-3kVA) UPS are with all high frequency, pure online, double-conversion, intelligent features. They are the perfect power security for file server, enterprise server, center server, mirco-computer, concentrator, telecom system, data center and others that require high quality power protection. They are widely applied to the many key business areas, such as post, finance, network, stock, railway, etc.

The (1-3kVA) UPS are with the single-phase AC input and single-phase AC output.

2.1.1 Model Meaning

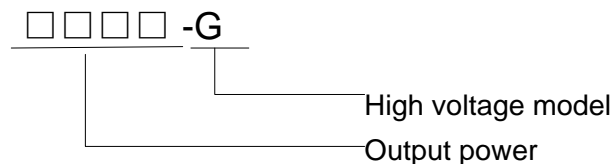

Figure2-1 The model meaning of (1-3kVA) UPS

The model meaning of (1-3kVA) UPS is as shown inFigure2-1. "□□□□" means the output power. When "□□□□" is "1kVA", it means the output power is 1kVA. When "□□□□" is "3kVA ", it means the output power is 3kVA. "G" means the product is high voltage model, if there is no "G", it means the product is low voltage model.

2.1.2 Features

USB communication

Through USB standard data port and UPS power management software, it can realize the three remote function between the computer and UPS, monitor the running and electrical data of UPS on the computer, perform ON/OFF operation remotely and support SNMP network adaptor, which makes UPS be a network new member.

High input power factor

Adopt the advanced active PFC technology, which eases load in the power grid. It is the new generation green power.

High cost performance

Adopt many kinds of power conversions and high frequency PWM technologies, which is with high efficiency, small volume, light weight, improves the running reliability and reduces cost.

Perfect protection

Equipped with the functions, such as output over-voltage protection, battery under-voltage protection, input over-voltage protection, triple over-current protection, etc. and solve the problems of the high frequency UPS, such as poor adaptability in the power grid and weak anti-impact ability.

Low mains input voltage

Adopt the independent rapid detection technology. When the mains input voltage is 120V, which is the lower limit, the battery still doesn't discharge. Therefore, in the mains mode, all output power gets from the power grid, which is to ensure the battery is still in the 100% energy storage status, reduce the battery discharge times and prolong the working life.

2.2 Appearance

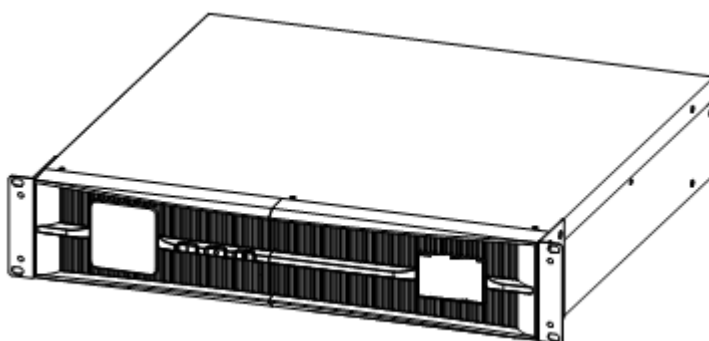

Figure2-2 Appearance of 1kVA

 **NOTE**

The appearance of (1-3kVA) UPS is similar, Figure2-2 takes 1kVA for an example.

2.2.1 Operation Panel

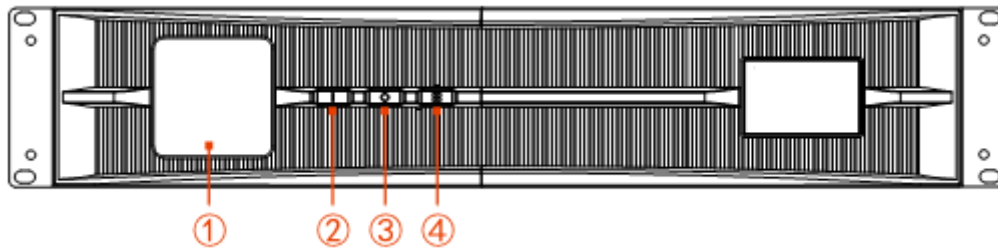

Figure2-3 Operation panel

Table2-1 The illustration of operation panel

No.	Icon	Name	Illustration
①	-	LCD	Display the working status and setting of UPS.
②	┆	"ON" button	<ul style="list-style-type: none"> When UPS is off, press and hold "┆" button for 1s to turn on UPS. When UPS is on and works in the mains mode, press and hold "┆" button for 3s to do the battery test. When UPS is on and works in the battery mode, press and hold "┆" button for 3s to silence the buzzer (cancel the mains abnormal alarm). Then press and hold "┆" button for 3s again to cancel silence. When UPS is on and works in the battery mode and with battery low-voltage alarm, press and hold "┆" button for 3s to silence the buzzer. Then press and hold "┆" button for 3s again to cancel silence..
③	○	"OFF" button	When UPS is on, press and hold "○" button for 1s to turn off UPS.
④	■ ■	"SELECT" button	<ul style="list-style-type: none"> Press "■ ■" button to transfer the display information, such as output voltage, output frequency, input voltage, input frequency, battery voltage, inner temperature, load percentage, fault information, etc. Press and hold "■ ■" button for 5s to enter the set page. Then press "■ ■" button to transfer the setting information, such as ECO/INV mode, TWR/RCK (TWR:

No.	Icon	Name	Illustration
			tower-mounting; RCK: rack-mounting) mode (the default setting is RCK mode) or the inverting output voltage that is 208V/230V (high voltage model) or 110V/120V (low voltage model), and press " I " button to confirm the setting.

LCD panel

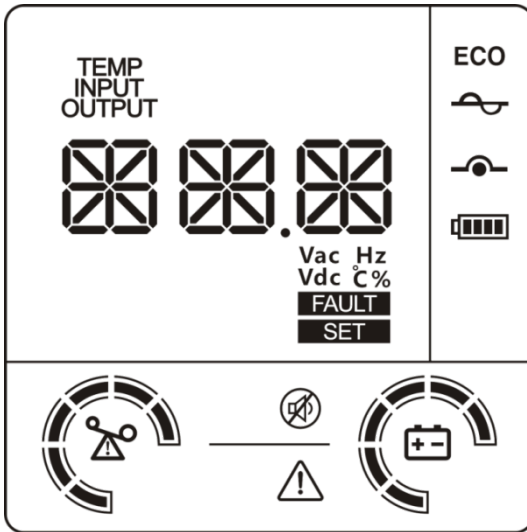



Figure2-4 LCD panel (rack-mounting display way)

Table2-2 The illustration of LCD panel

No.	Icon	Illustration
1		It shows input voltage, input frequency, output voltage, output frequency, load percent, temperature, fault code, parameters or working mode, etc.
2		UPS works in the mains mode
3		UPS works in the bypass mode
4		UPS works in the battery mode

No.	Icon	Illustration
5	ECO	UPS works in the ECO mode
6		Buzzer is in the silence status
7		UPS failure

2.2.2 Rear Panel View

1kVA

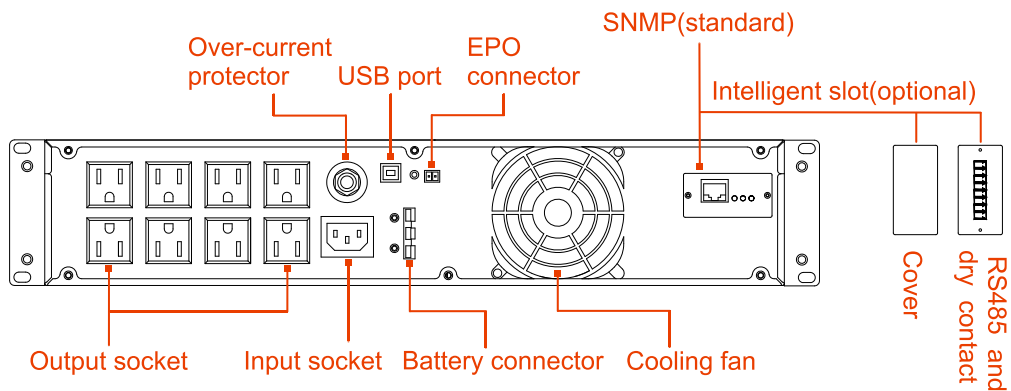

Figure2-5 Rear panel of 1kVA

2kVA

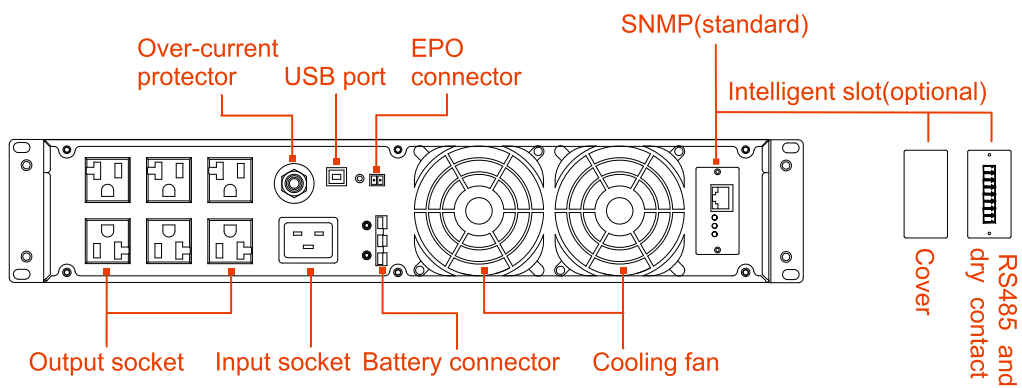

Figure2-6 Rear panel of 2kVA

2.2kVA

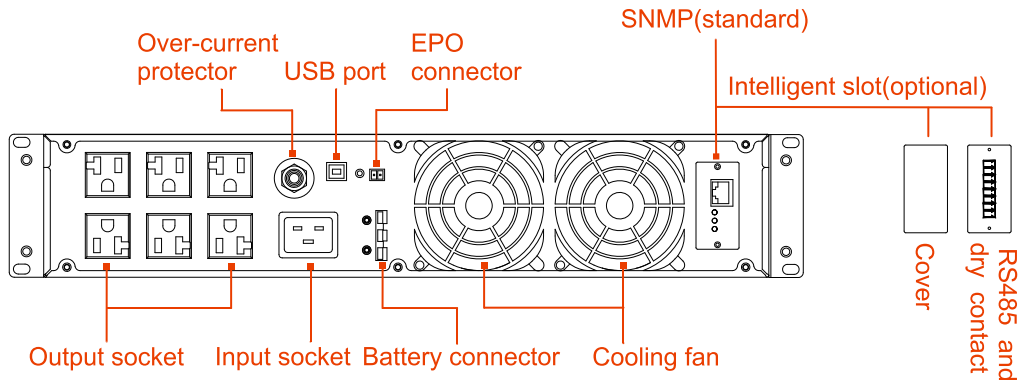

Figure2-7 Rear panel of 2.2kVA

3kVA

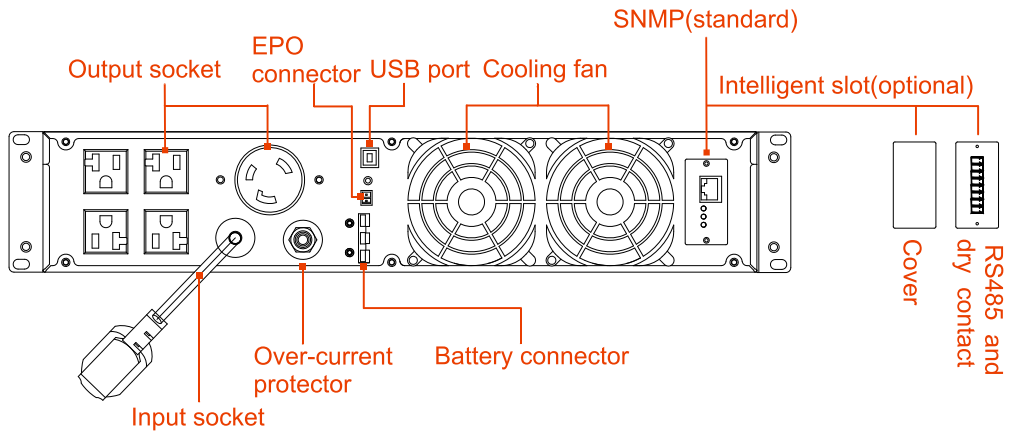

Figure2-8 Rear panel of 3kVA

2kVAG/ 2.2kVAG/3kVAG

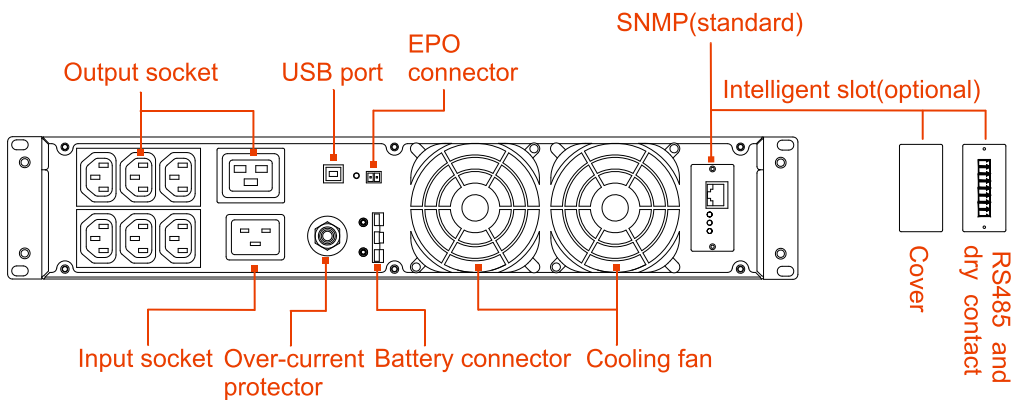

Figure2-9 Rear panel of 2kVAG/ 2.2kVAG/ 3kVAG

2.2.3 EPO Connector

When connecting two ports in the EPO connector together, UPS will close output. If it needs to recover output, disconnect two ports in the EPO connector and power UPS off, and then restart UPS.

2.2.4 Intelligent Slot

SNMP card

SNMP card can achieve the remote monitor for the input voltage and frequency, output voltage and frequency, load, etc. of the UPS and remote ON/OFF operation, as shown in Figure2-10.

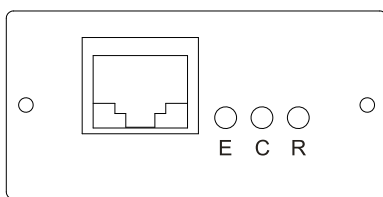

Figure2-10 SNMP card

RS485 and dry contact (optional)

The pin sequence and pin definition of RS485 and dry contact is as shown in Figure2-11 and Figure2-12.



Figure2-11 RS485 and dry contact

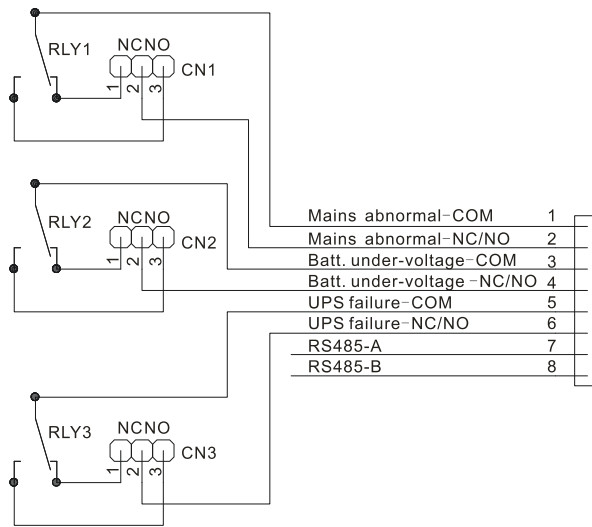

Figure2-12 Pin definition of RS485 and dry contact

The illustration of dry contact is as below:

1. CN1, CN2, CN3 determine that dry contact output signal is normal open or normal close. In default, dry contact output signal is normal close, that is to say PIN1 connects with PIN2. If one route signal needs to set to normal open, connect PIN2 with PIN3.
2. The requirements for input signal of dry contact: the voltage should be less than 60Vdc or 42Vac RMS and the current should be less than 1.25A.

2.3 Working Principles

When the mains is normal, the input of (1-3kVA) UPS converts into the $\pm 360V$ (high voltage model)/ $\pm 180V$ (low voltage model) steady DC voltage through PFC, which supplies power for DC/AC inverter to output steady 208V/230V (high voltage model) or 110V/120V (low voltage model) AC and charges battery at the same time. When the mains is abnormal, the battery will boost into the $\pm 380V$ (high voltage model)/ $\pm 190V$ (low voltage model) DC voltage for DC/AC inverter through DC/DC.

The working principles of (1-3kVA) UPS is as shown in Figure2-13. The DC/AC inverter adopts half bridge structure and the DC/DC boost adopts the push-pull circuit or boost circuit. PFC is the correction circuit for active power factor.

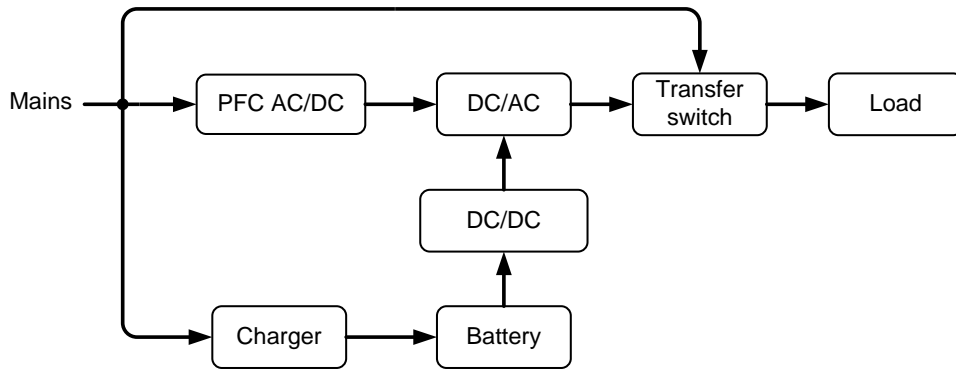

Figure2-13 The working principle of (1-3kVA) UPS

2.3.1 Fault Status

UPS faults include: EPO protection, busbar voltage fault, IGBT over-temperature fault, fan fault (including fan blocked, fan damage, etc.), output fault (including output overload protection, output short-circuit, etc.), battery fault (including battery over-voltage protection, battery under-voltage protection, etc.), etc. The corresponding fault status displayed in the LCD (rack-mounting display way) is as shown in Figure2-14 to Figure2-20.

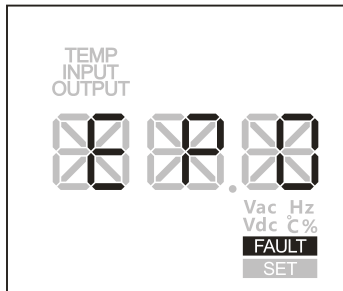

Figure2-14 EPO protection

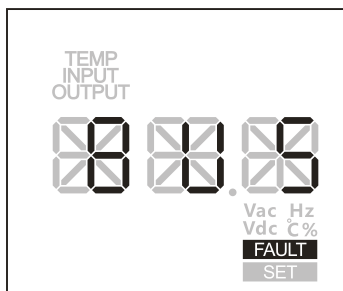

Figure2-15 Busbar voltage fault

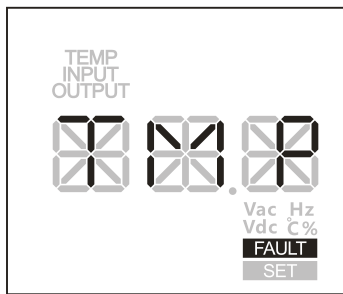

Figure2-16 IGBT over-temperature fault

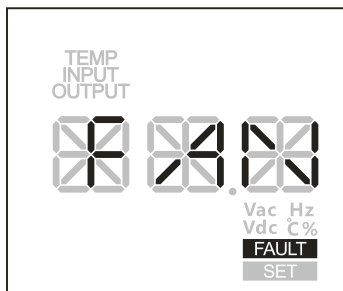

Figure2-17 Fan fault

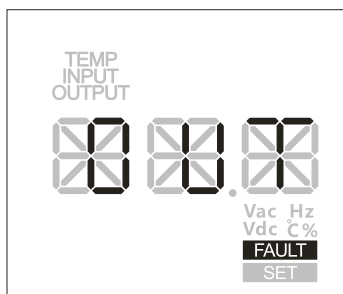

Figure2-18 Output fault

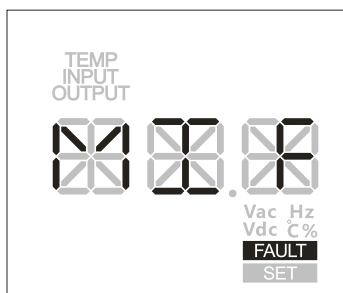

Figure2-19 Multiple inverting fault

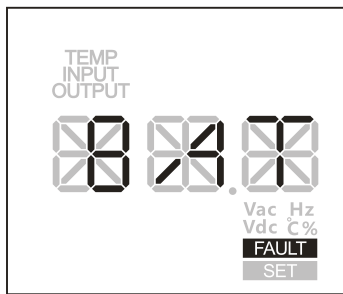

Figure2-20 Battery fault

2.3.2 UPS Parameters Setting

Press and hold "■" button for 5s to enter the set page. Then press "■" button to transfer the setting information, such as ECO/INV mode, TWR/RCK (TWR: tower-mounting; RCK: rack-mounting) mode (the default setting is RCK mode) or the inverting output voltage that is 208V/230V (high voltage model) or 110V/120V (low voltage model), and press "↓" button to confirm the setting.

ECO mode

"ECO" set page: In the set page, three characters "ECO" flicker. If you confirm the selection, press and hold "↓" button more than 1s to quit the set page, the setting is successful. If you aren't sure the selection, it will quit the set page 20s later automatically. In the ECO mode, the LCD display is as shown Figure2-21.

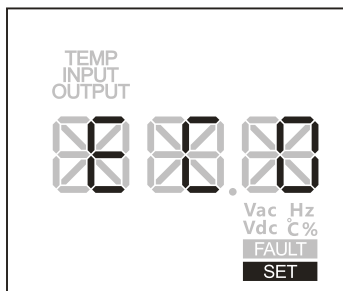

Figure2-21 ECO mode

INV mode

"INV" set page: In the set page, three characters "INV" flicker. If you confirm the selection, press and hold "↓" button more than 1s to quit the set page, the setting is successful. If you aren't sure the selection, it will quit the set page 20s later automatically. In the INV mode, the LCD display is as shown Figure2-22.

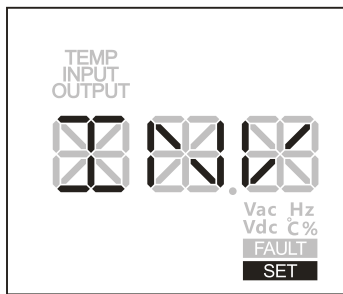

Figure2-22 INV mode

RCK mode

The default setting is RCK mode. When LCD displays TWR mode and it has to set to RCK mode, in the set page, three characters "RCK" flicker. If you confirm the selection, press and hold "↓" button more than 1s to quit the set page, the setting is successful. In the RCK mode, the LCD display is as shown Figure2-23.

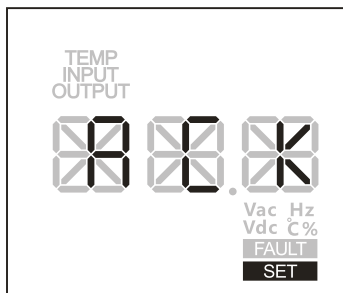

Figure2-23 RCK mode

TWR mode

When LCD displays RCK mode and it has to set to TWR mode, in the set page, three characters "TWR" flicker. If you confirm the selection, press and hold "↓" button more than 1s to quit the set page, the setting is successful. In the TWR mode, the LCD display is as shown Figure2-24.

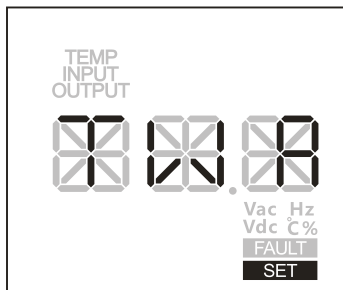

Figure2-24 TWR mode

The setting of the inverting output voltage that is 208V/230V (high voltage model) or 110V/120V (low voltage model) is the same to the above method.

3 Installation

This chapter mainly describes installation, including installation announcements, installation preparation, unpacking and checking, installation procedures, electrical connection, electrical connection checking, etc.

3.1 Installation Announcements

As the (1-3kVA) UPS is small, it can put UPS on the flat surface directly without other fixed or installation. Keep a clearance at least 300mm~500mm around UPS and 500mm on the top of UPS, which is good for operation or maintenance or heat dissipation. Keep UPS with good ventilation. In the room temperature (20°C), the working life of battery is the longest. Therefore, if conditions allow, it is recommended to install air-condition. The installation announcements are as shown in Figure3-1.

- Put UPS on the flat floor (do not put it on the tilted or uneven floor).
- Don't put objects on the top of UPS or around UPS to avoid blocking air vent. People can't sit on the top of UPS.
- Avoid putting UPS in the direct sunshine, rain or damp place.
- Don't put UPS in the place with corrosive gas.
- Don't put UPS near fire or all electrical equipments which easily cause sparks to avoid human injury or unnecessary loss.

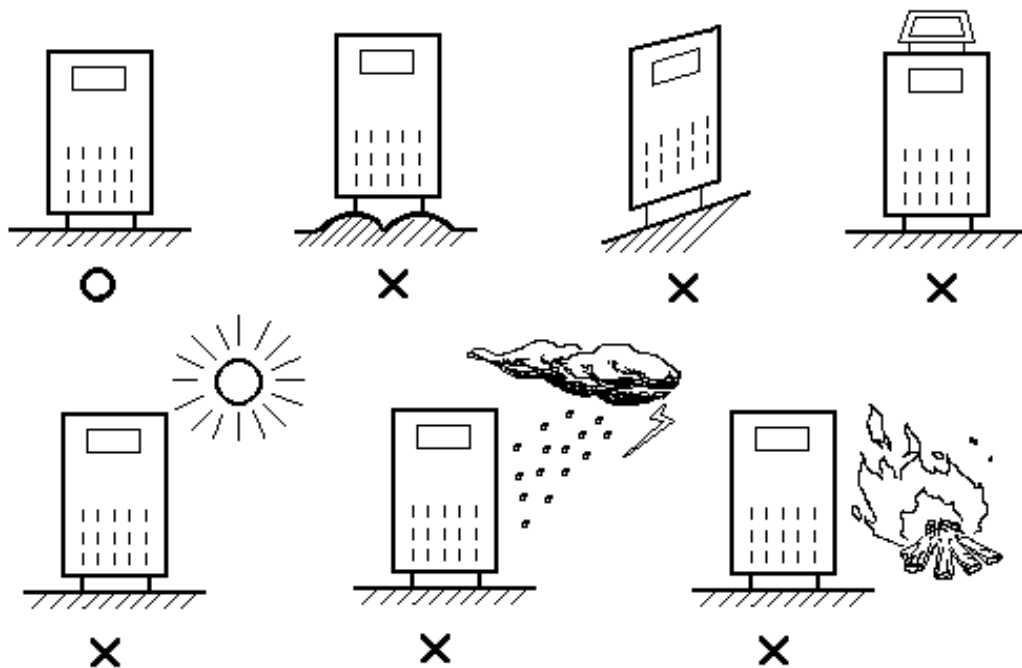

Figure3-1 The installation announcements for UPS

3.2 Installation Preparation

3.2.1 Installation Place and Environment Requirements



CAUTION

Before attempting to install UPS, the installation place and environment should meet the basic condition for safety and normal running. If not, please do the corresponding change. If the basic conditions are all met, install UPS.

Installation place requirements

- The installation place must be equipped with fire-fighting equipments.
- The mains supplying power for UPS should be equipped with specified breaker or multi-functional sockets.
- It is prohibited to put flammable and explosive objects in the installation place.
- Before attempting to install UPS, it should do the grounding preparation. The Neutral-to- Ground voltage in the mains should be less than 5V.

- The construction of installation place should have been finished and the floor has been hardened. The installation place should be clean and without dust.

Installation environment requirements

- Operating temperature: 0~60°C (Peak operating Temperature is 0~40°C. Prolonged operation between 40~60°C may affect output wattage);
- Relative humidity: 0%RH~95%RH, with no condensation;
- Cooling way: air-cooling;
- Operating altitude: meet GB3859.2-93 requirements;
- Verticality: without vibration and the vertical gradient should be not more than 5°;
- Pollution grade: grade II.

UPS should be installed in the place where is with good ventilation, proper temperature and humidity, and without dust. The recommend environment temperature is 20~25°C and humidity is about 50%RH.



CAUTION

Don't install UPS in the place with metal conductive dust. UPS is only suitable to use in the non-tropical climate conditions.

3.2.2 Input Breaker Selection

Add a breaker or a power distribution box in the input wire of UPS, which matches with the power of UPS, to isolate the mains. Consider the charging power of UPS and the transient current impact when power on, the current of the selected breaker should be 1.5~2 times of the max. input current of UPS. Besides, the selected breaker should be without the power leakage protection to prevent misoperation. The distribution box is better to be made by the professional company. The selection of input breaker refers to Table3-1.

Table3-1 The recommended input breaker of (1-3kVA) UPS

Model	AC input	
	Max. current(A)	Recommended breaker(A)
1kVA	12	20
2kVA	24	32
2.2kVA	26	32
3kVA	36	50
1kVAG	12	20
2.2kVAG	12	20
3kVAG	18	32

3.2.3 Selection of the Cross-sectional Area of Wire

For the selection of the cross-sectional area of AC input wire, AC output wire and battery wire of (1-3kVA) UPS, please refer to Table3-2 for the corresponding recommended value and choose upwards.

Table3-2 The recommended cross-sectional area of wire

Cross-sectional area(mm ²)		1	1.5	2.5	4	6	10	16	25
Ampacity(A)	Rubber (25°C)	8	12	20	28	42	70	96	125
	Plastic (25°C)	6	9	15	20	30	50	64	100

NOTE

The equipped wires are with good quality and meet safety requirements, which pass international authentication and UL authentication. If user prepares wires by themselves, please refer to the recommended cross-sectional area of wire that is about 5m length listed in Table3-2. Longer wires require larger cross-sectional areas.

3.3 Unpacking and Checking

Unpacking UPS and conduct the following items:

- Inspect the appearance for shipping damage. If any shipping damage is found, report it to the carrier immediately.
- Check the delivery list to see if the types of accessories are complete and correct. If there is any discrepancy, contact the distributor immediately.

3.4 Installation Procedures

3.4.1 UPS Installation



NOTE

The UPS installation for (1-3kVA) UPS is similar, the following takes 1kVA for an example.

Rack-mounting

Step 1 Install angle iron (two pieces) on UPS by four pieces of M4*8FMC screws.

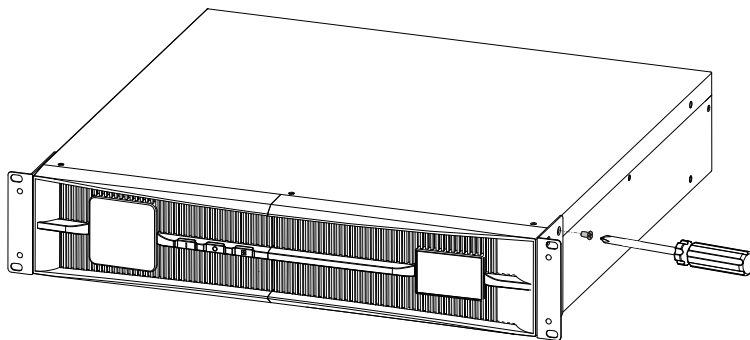

Step 2 Push UPS into rack.

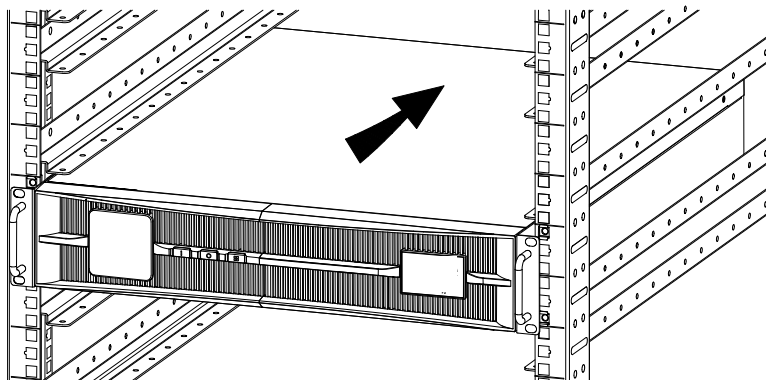

Step 3 Fix UPS on the rack by screws.

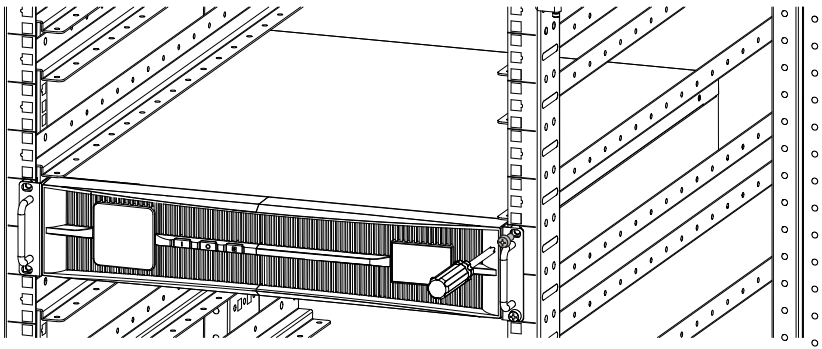

----End

Tower-mounting

Step 1 Keep UPS upright, the side with battery should be up.

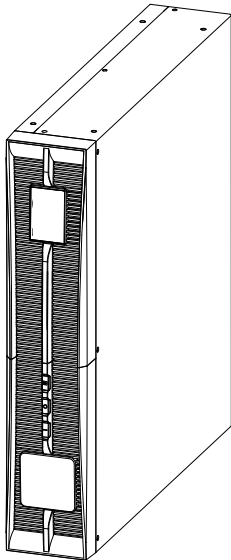

Step 2 Install two bearings together.

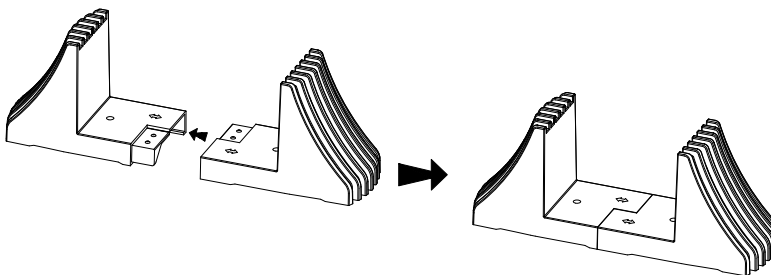

Step 3 Fix the bearing (two pieces) on UPS by two pieces of M4*10TMC screws.

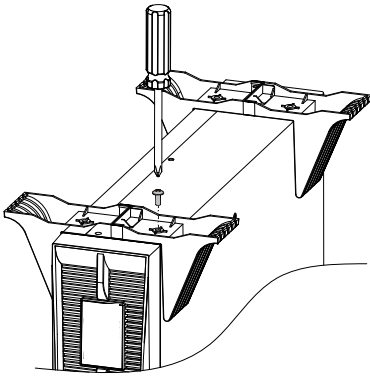

Step 4 Place UPS with bearings as below and set the display ways as tower-mounting, the detail refers to 2.2.1 .

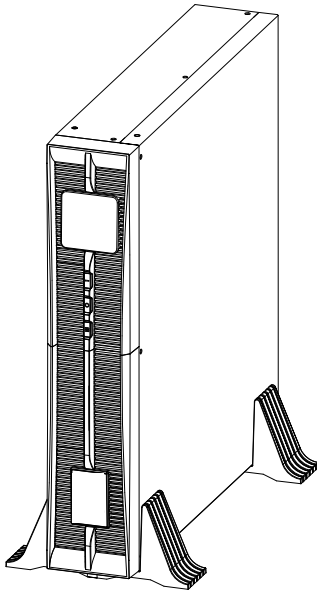

----End

3.4.2 Intelligent Slot Replacement

 **NOTE**

The intelligent slot replacement for (1-3kVA) UPS is similar, the following takes 1kVA for an example.

Step 1 Dismantle standard intelligent slot.

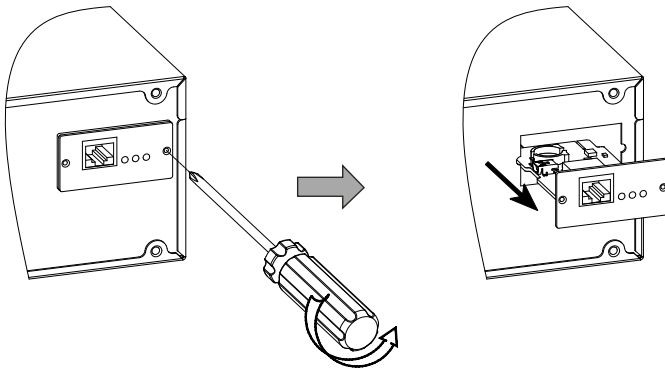

Figure3-2 Dismantle standard intelligent slot

Step 2 Install optional intelligent slot and fix it.

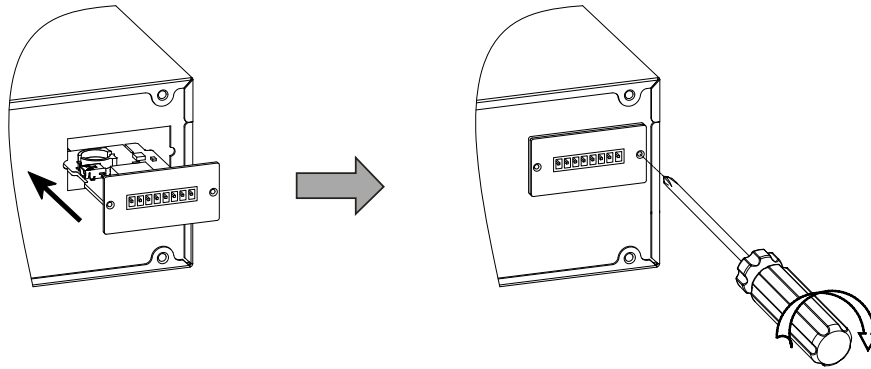

Figure3-3 Install optional intelligent slot

Step 3 Connect communication cable.

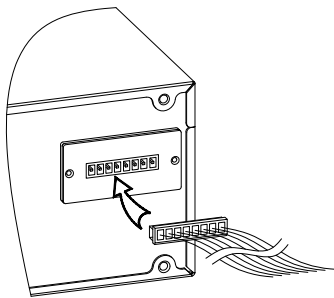

Figure3-4 Connect communication cable

----End

3.5 Electrical Connection

3.5.1 Battery Connection

 **NOTE**

The battery connection for (1-3kVA) UPS is similar, the following takes 1kVA for an example.

In default, battery connector hasn't been connected with UPS to prevent misoperation during transportation. After installing UPS, take battery connector out of package and then insert it into the battery port in the rear panel of UPS, as shown in Figure3-5.

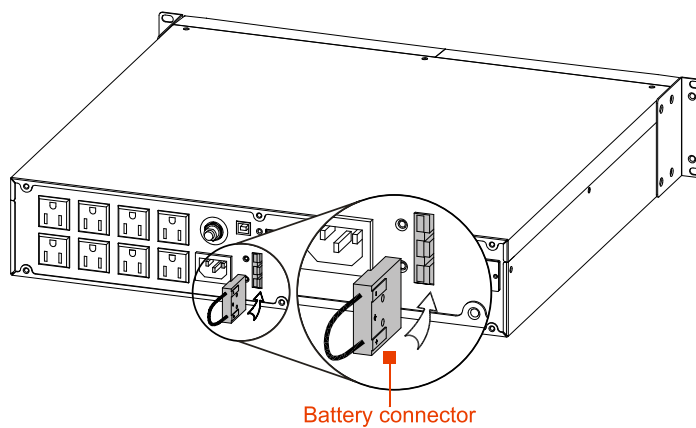

Figure3-5 Battery connection

3.5.2 Wire Connection

The AC input and output of (1~3kVA) UPS are sockets. Connect input socket with mains socket by power wire and plug load power wire in the output socket.



CAUTION

Mains socket should be installed near UPS and it is convenient to operate.

1kVA

The wiring for the input and output of the 1kVA UPS is as shown in Figure3-6.

**CAUTION**

Each output socket current shouldn't be more than 15A, the total output current shouldn't be more than 9A.

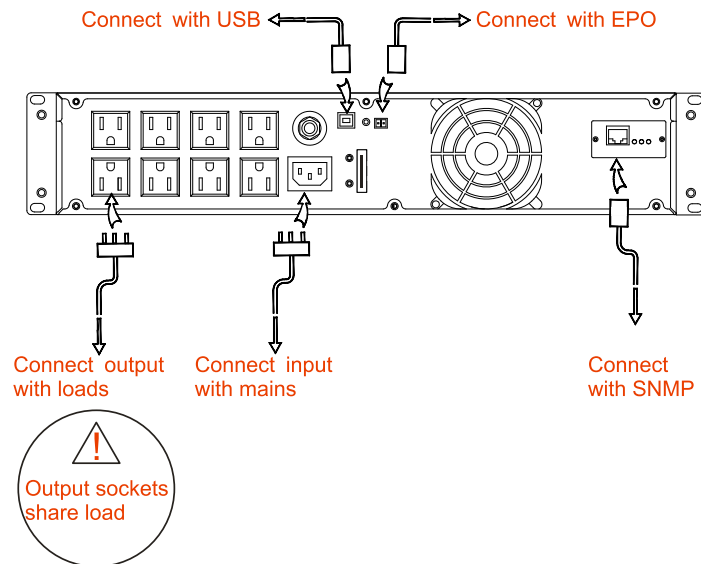

Figure3-6 Wiring diagram of 1kVA

2kVA

The wiring for the input and output of the 2kVA UPS are as shown in Figure3-7.

**CAUTION**

Each output socket current shouldn't be more than 20A, the total output current shouldn't be more than 18A.

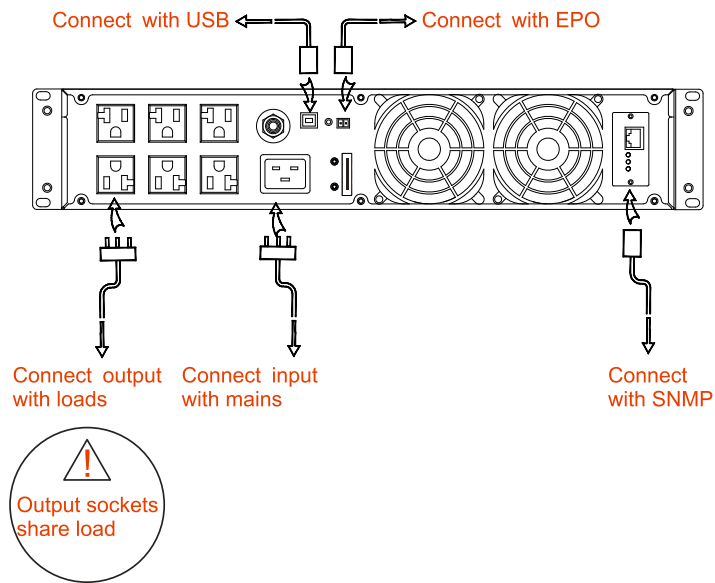

Figure3-7 Wiring diagram of 2kVA

2.2kVA

The wiring for the input and output of the 2.2kVA UPS are as shown in Figure3-8.



CAUTION

Each output socket current shouldn't be more than 20A, the total output current shouldn't be more than 20A.

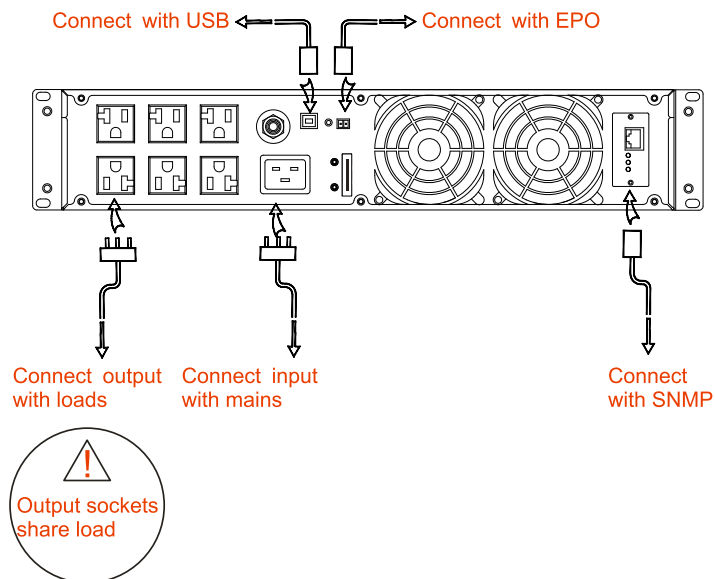

Figure3-8 Wiring diagram of 2.2kVA

3kVA

The wiring for the input and output of the 3kVA UPS are as shown in Figure3-9.

**CAUTION**

Each output socket current shouldn't be more than 20A, the total output current shouldn't be more than 27A.

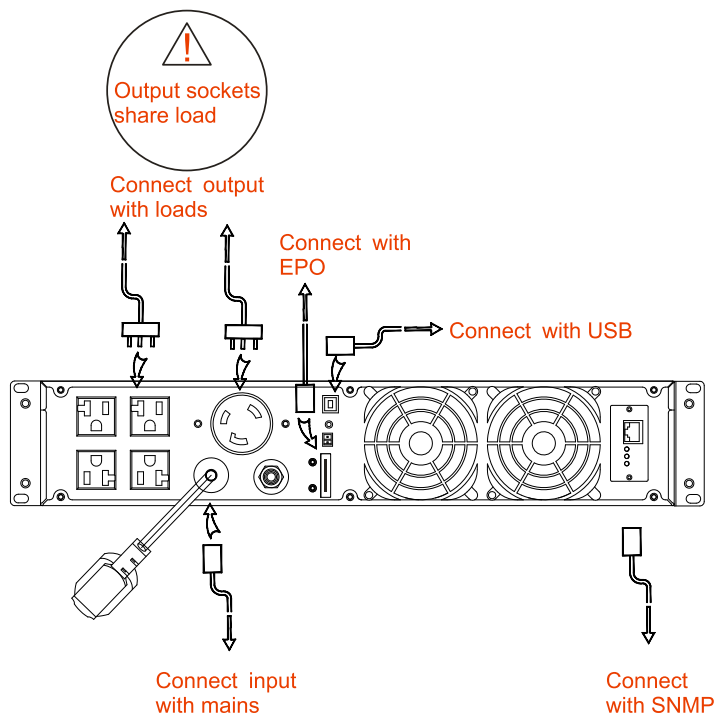

Figure3-9 Wiring diagram of 3kVA

2kVAG/ 2.2kVAG/ 3kVAG

The wiring for the input and output of the 2kVAG/ 2.2kVAG/ 3kVAG UPS are as shown in Figure3-10.



CAUTION

- 2kVAG: Each output socket current shouldn't be more than 10A, the total output current shouldn't be more than 9.6A.
- 2.2kVAG: Each output socket current shouldn't be more than 10A, the total output current shouldn't be more than 10.5A.
- 3kVAG: Each output socket current shouldn't be more than 10A, the total output current shouldn't be more than 14A.

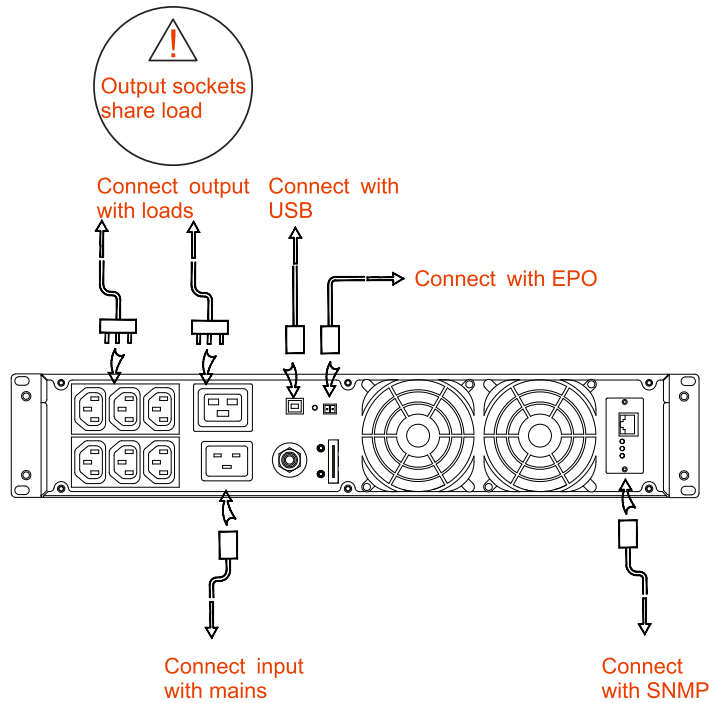

Figure3-10 Wiring diagram of 2kVAG/2.2kVAG/ 3kVAG

3.6 Electrical Connection Checking

After finishing electrical connection, perform electrical connection checking according to Table3-3.

Table3-3 Electrical connection checking

No.	Check items	Result
1	Check whether the wires are connected firmly.	Yes <input type="checkbox"/> No <input type="checkbox"/>
2	Check whether the Neutral-to Ground voltage is less than 5Vac.	Yes <input type="checkbox"/> No <input type="checkbox"/>

No.	Check items	Result
3	Check whether the wiring is neat and the wire binding is in accordance with process specification.	Yes <input type="checkbox"/> No <input type="checkbox"/>
4	Check whether the installation and wiring are good for system reformation, expansion and maintenance in future.	Yes <input type="checkbox"/> No <input type="checkbox"/>

4 Operation Guide

This chapter mainly describes the checking before startup, startup and shutdown operation, etc.

4.1 Checking Before Startup

Before using UPS, check the following items to ensure that UPS works normally.

- The installation of input and output are correct.
- The input power connects with the rated input power.
- There is no short-circuit in the output and the load capacity is not beyond the UPS capacity.
- Whether computer or other equipments are switched off.
- Whether the battery voltage is normal.
- It isn't recommended to connect with the inductive load in the output. Generally, grid supplies power for the inductive load directly.

4.2 Startup Operation

- Step 1 Connect UPS with mains socket.
- Step 2 Press " | " button on the panel for 1s to start UPS.
- Step 3 About 10s later, if the UPS works steadily, start loads, such as PC, etc.



CAUTION

Start load with the sequence that "high power device→small power device", which is to avoid overload protection when starting high power device.

----**End**

4.3 Shutdown Operation

Step 1 Close load and keep UPS running without load for about 10 minutes to exhaust heat.

Step 2 Press "○" button on the panel for 1s to shut down UPS.

Step 3 Unplug mains socket.

----End

5 Maintenance and Troubleshooting

This chapter mainly describes maintenance guide, daily battery maintenance, replacing battery announcements and troubleshooting.

5.1 Maintenance Guide

Proper maintenance is the key that the device works on the best status and with a longer service life.

5.1.1 Safety Precautions

To ensure human safety and device security, observe the following precautions.

- Remember that even though UPS doesn't work, there may still exist dangerous voltage inside UPS. Before maintenance, use a multi-meter to check the voltage and make sure that UPS is completely shut down and stay in safe status.
- The operator should be familiar with UPS and user manual.
- Before operating UPS, take off conductive objects, such as rings, watches.
- Observe safety regulations strictly. If any doubt, consult professionals.
- Before maintenance, use a voltmeter to check the power is turned off and in a safety condition.

5.1.2 Preventive Maintenance

To improve the efficiency and reliability of UPS, do the following maintenance tasks regularly.

- Keep operation environment free from dust and chemical pollutant.
- Check whether fans work properly and air vents are not blocked. If some fans stop working, replace them in time.
- Check whether battery voltage is normal.
- Check whether UPS works normally.

5.2 Daily Battery Maintenance

- Charging requirements of battery.
 - When using battery for the first time, start UPS to charge battery for ten hours. During charging, you still can use UPS. If UPS and battery are power down simultaneously, the discharging time of battery may be lower than standard this time.
 - Generally, charge and discharge battery once every four to six months. Discharging battery until UPS turns off. Then charge them. The charging time should be no less than ten hours.
 - In high-temperature areas, charge and discharge battery once every two months. The charging time should be no less than ten hours.
 - If battery has not been used for a long time, charge and discharge them once every three months. The charging time should be no less than ten hours.
- Clean battery shells by water-dipped cloth. Oil and organic solvents, such as petrol and diluents are prohibited.
- To avoid explosion, keep battery far away from fire sources and devices that easily generate sparks.
- When using the battery pack connected with UPS, check whether charger is OK regularly to avoid battery on the overcharging status or incomplete charging status. It should avoid over discharging battery. After discharging, it should charge battery completely (The time should be less than 24h). It is prohibited that the incomplete charging battery discharges again, which will reduce the battery capacity, even damage battery.
- Press "○" button to shut down UPS which is to avoid battery discharging for a long time after mains powers down. If UPS stops working for a long time, it should charge and discharge battery periodically, which is to avoid battery damage for self-discharge.

5.3 Replacing Battery Announcements

- Don't put battery into fire to avoid explosion.
- Don't open or dismantle battery. The inner electrolyte is harmful to our skin and eyes.
- Recycle battery according to the instructions appropriately.
- Consult professionals for replacing battery.
- A new battery should be with the same capacity, model, and manufacturer as the replaced one.

- Check whether there exists dangerous voltage between battery terminals and ground before touching, which is to avoid human injury. It is prohibited to touch the battery's two wire connectors or bare terminals for wiring simultaneously.

5.4 Troubleshooting

After starting UPS, if UPS works abnormally, please refer to Table5-1 to find possible reason. Meanwhile, check whether the fault is caused by external environment, such as temperature, humidity are not accordance with requirements or UPS is overload.

Table5-1 only includes some simple diagnosis. If the diagnosis is not clear, or not sufficient to solve problem, please contact with local agency or dealer to deal with.

Table5-1 Troubleshooting

No.	Phenomenon	Possible reasons
1	The mains is normal. When starting UPS, it can output 208V/230V (high voltage model) or 110V/120V (low voltage model) AC. But UPS works in the battery inverting status, and the buzzer beeps intermittently.	Make poor connection in the contacts of grid feeding circuit or sockets, which will lead to power input is not expedite.
2	When starting UPS, it can output 208V/230V (high voltage model) or 110V/120V (low voltage model) AC. But UPS works in the bypass status ("⚡" indicator is always on.)	(1) The load exceeds the rated output capacity of UPS. It should reduce load or select UPS with larger output capacity. (2) It is normal that shock from load startup leads to turn into bypass mode temporarily and recovery automatically
3	After starting UPS, output is normal. But when starting load, UPS will stop output immediately.	(1) If UPS is serious overload or output is short circuit, it should reduce load to proper or find reason of short circuit. The common reason is that the output multi-tap is short circuit or the input is short circuit after device is damaged,. (2) If you does not follow the startup sequence that is "high power device → small power device" to

No.	Phenomenon	Possible reasons
		start load, restart UPS. When UPS works steadily, restart load following the sequence.
4	After starting UPS, UPS works normally. After a while, UPS will shutdown automatically.	In the battery mode, it is normal that UPS turns off automatically when battery runs out and takes battery low voltage protection. When mains is normal, system will start automatically and charge battery.
5	Buzzer long beeps, fault indicator is on, inverter failure and UPS turns to bypass mode.	(1) Load overload or output short circuit, UPS will turn off automatically. (2) Drive or power transistor failure. (3) Main control board failure. (4) UPS over-temperature protection
6	After starting UPS, UPS works normally. When mains powers down, UPS has no output.	(1) Battery failure. (2) Battery charger failure. Generally, it can't charge battery. (3) Battery hasn't been connected with UPS or battery has been damaged seriously.
7	The input is normal, but buzzer still beeps intermittently.	The mains voltage or frequency is out of the range of UPS requirements.
8	Indicators on the panel are all off.	The wiring for display board is unreliable or fault.

If UPS failure, press "■" button. It can view the UPS failure prompting on the LCD, which is good for finding the fault source quickly.

The meaning of fault symbol and buzzer status is shown in Table5-2.

Table5-2 The meaning of fault symbol and buzzer status

Fault symbol		Buzzer status	Meaning
Fault info. page (page up or page down)	EPO	Long beep	UPS has emergency protection (if equipped with EPO function), Bypass output and inverting output are all closed.

Fault symbol	Buzzer status	Meaning	
by "  " button)	BUS	Long beep	There has busbar voltage fault in the UPS, the inverting output is closed.
	TMP	Long beep	UPS has over-temperature protection, the inverting output is closed. Please check if cooling fan damage and air vents blocked.
	OUT	Long beep	Output fault, please check if output is short-circuit or the load is too large.
	MIF	Long beep	Check whether UPS is on and works in the bypass mode. If yes, UPS has more than five times inverting fault within five minutes. Check whether UPS output connects with inductive load or the output load is too large.
	BAT	Long beep	Battery fault, battery voltage too low or too high protection.
	FAN	Rapid beep (Alarm once about every 0.2s)	Fan fault alarm prompting, the inverting output is going to protect. Please check if cooling fan damage.
Load energy bars all flicker	Rapid beep (Alarm once about every 0.2s)	Output overload alarm. The output is going to close, please reduce load.	
Battery energy bar all flicker	Slow beep (Alarm once about every 2.0s)	Battery voltage is too high. Please check if battery or charger failure.	
Battery energy bars are all off and the frame flickers	Rapid beep (Alarm once about every 0.2s)	Battery is about to run out. Please pay attention to protect device and save your data in the PC.	

6 Package, Transportation, Storage

This chapter mainly describes the announcements about the package, transportation, storage.

6.1 Package

The package of product is carton. When packing, pay attention to the placing direction requirements. On one side of the carton, it should print warning icons, including keep dry, handle with care, this end up, stacking layer limit, etc. On the other side of carton, paste the model type, etc.

6.2 Transportation

When transportation, handle the UPS with care. Don't impact it severely. It should strictly follow the placement direction that shows on the carton to avoid UPS damage.

6.3 Storage

UPS should be stored in the dry warehouse. Don't put it under the sunshine or in the rain. It should follow the placement direction that shows on the carton. The storage environment temperature is $-25\sim+55^{\circ}\text{C}$ (no battery). If it is the standard UPS or the storage batteries, the recommended storage temperature is $0\sim40^{\circ}\text{C}$, the relative humidity is 20%~80%.In warehouse, It's prohibited that there has poisonous gas, objects that inflammable and explosive, corrosive chemical objects. Besides, it shouldn't have too strong mechanical shaking, impact and strong magnetic field. Under the storage conditions above, the storage period is six months. If it is long time storage, it should charge the storage battery every three months.

A Technical Specifications

A.1 1kVA/ 2kVA/ 2.2kVA/ 3kVA

Model		1kVA	2kVA	2.2kVA	3kVA
Index					
Input features	Voltage range (V)	When the voltage range is 88Vac~148Vac, it can connect with more than 75% load; when the voltage range is 77Vac~88Vac, it can connect with 50~75% load; when the voltage range is 60Vac~77Vac, it can connect with less than 50% load.			
	Frequency range (Hz)	50/60±10% (50/60 self-adaption)			
	Input method	Single phase three wire			
	Battery voltage (V)	24	48	72	72
Output features	Power capacity (VA/W)	1000/1000	2000/2000	2200/2200	3000/3000
	Voltage (V)	110/120±1% (settable)			
	Frequency (Hz)	50/60±0.2% (battery mode)			
	Wave	Sine-wave			
	Voltage distortion	THD <3% (linear load)			
	Power factor	1.0			
	Transfer time between battery mode	0			

Index		Model		1kVA	2kVA	2.2kVA	3kVA
		and mains mode (ms)					
Overload ability	Low overload for 1min	1050VA/1050W < Load≤1300VA/1160W	2100VA/2100W < Load≤2600VA/2320W	2200VA/1980W < Load ≤ 2860VA/2080W	3150VA/3150W < Load≤3900VA/3480W		
	Medium overload for 1s	1300VA/1160W < Load≤1500VA/1330W	2600VA/2320W < Load≤3000VA/2660W	2860VA/2080W < Load ≤ 3300VA/2080W	3900VA/3480W < Load≤4500VA/3990W		
	High overload for 200ms	Load > 1500VA/1330W	Load > 3000VA/2660W	3300VA/2080W <Load	Load > 4500VA/3990W		
Output receptacles		Eight 5-15R sockets with 15A	Six 5-20R sockets with 20A	Six 5-20R sockets with 20A	Four 5-20R sockets with 20A and one L5-30R with 30A		
Other features	Backup time	11mins					
	Charge time	≤5h					
	Communication interface	Standard: SNMP adapter and USB port support UPS power management software; Optional: RS485 and dry contact.					
	Display	LCD displays the running status of UPS.					
	Alarm function	Battery low-voltage, mains abnormal, UPS fault, output overload					
	Protection function	Battery under-voltage protection, overload protection, short-circuit protection, over-temperature protection, input over-voltage protection					
	Noise (dB)	<55					

Index \ Model		1kVA	2kVA	2.2kVA	3kVA
	Operating temperature (°C)	The operating temperature is 0~60°C (Peak operating Temperature is 0~40°C. Prolonged operation between 40~60°C may affect output wattage)			
	Relative humidity	0~95%, non-condensation			
	Dimensions (mm) (width*depth*height)	438*420*87	438*570*87	438*615*87	438*570*87
	Weight (kg)	8.89	13.6	19.1	17.1

A.2 2kVAG/ 2.2kVAG/ 3kVAG

Index \ Model		2kVAG	2.2kVAG	3kVAG
Input features	Voltage range (V)	When the voltage range is 176Vac~295Vac, it can connect with more than 75% load; when the voltage range is 154Vac~176Vac, it can connect with 50~75% load; when the voltage range is 120Vac~154Vac, it can connect with less than 50% load.		
	Frequency range (Hz)	50/60 ± 10% (50/60 self-adaption)		
	Input method	Single phase three wire		
	Battery voltage (V)	48	72	72
Output features	Power capacity (VA/W)	2000/2000	2200/2200	3000/3000
	Voltage (V)	208/230±1% (settable)		
	Frequency (Hz)	50/60±0.2% (battery mode)		
	Wave	Sine-wave		

Index		Model		2kVAG	2.2kVAG	3kVAG
		Voltage distortion		THD <3% (linear load)		
Power factor		1.0				
Transfer time between battery mode and mains mode (ms)		0				
Overload ability	Low overload for 1min	2100VA/2100W < Load ≤ 2600VA/2320W	2200VA/1980W < Load ≤ 2860VA/2080W	3150VA/3150W < Load ≤ 3900VA/3480W		
	Medium overload for 1s	2600VA/2320W < Load ≤ 3000VA/2660W	2860VA/2080W < Load ≤ 3300VA/2080W	3900VA/3480W < Load ≤ 4500VA/3990W		
	High overload for 200ms	Load > 3000VA/2660W	3300VA/2080W < Load	Load > 4500VA/3990W		
Output receptacles		One IEC C19 socket with 16A and six IEC C13 sockets with 10A				
Other features	Backup time	11mins				
	Charge time	≤ 5h				
	Communication interface	Standard: SNMP adapter and USB port support UPS power management software; Optional: RS485 and dry contact.				
	Display	LCD displays the running status of UPS.				
	Alarm function	Battery low-voltage, mains abnormal, UPS fault, output overload				
	Protection function	Battery under-voltage protection, overload protection, short-circuit protection, over-temperature protection, input over-voltage protection				

A Technical Specifications

Model		2kVAG	2.2kVAG	3kVAG
Index				
	Noise (dB)	<55		
	Operating temperature (°C)	The operating temperature is 0~60°C (Peak operating Temperature is 0~40°C. Prolonged operation between 40~60°C may affect output wattage)		
	Relative humidity	0~95%, non-condensation		
	Dimensions (mm) (width*depth*height)	438*420*87	438*615*87	438*570*87
	Weight (kg)	13.6	19.1	16.1

- Specifications are subject to change without prior notice.

B Acronyms and Abbreviations

A

AC Alternating Current

D

DC Direct Current

E

ECO Energy Control Operation

EPO Emergency Power Off

I

IEC International Electrotechnical Commission

L

LCD Liquid Crystal Display

P

PE Protective Earthing

R

RS232 Recommend Standard232

S

SNMP Simple Network Management Protocol

U

UPS Uninterruptible Power System

USB Universal Serial Bus

